

lumenpulse™

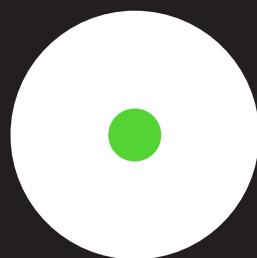
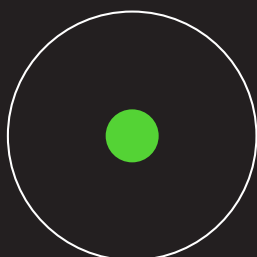
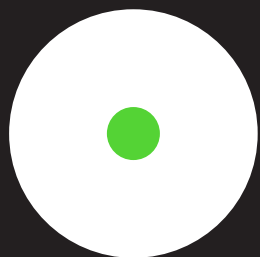

exenia
Pendant Luminaires

The Exenia Story

A RICH HISTORY

Exenia's formation in 2010 resulted from multiple passionate individuals with a long history of lighting experience joining to celebrate, innovate, and create outstanding lighting. Exenia has been a part of LMPG since 2015, which has allowed for an ongoing exchange of ideas and technology between Lumenpulse and Exenia. The synergy between these passionate minds and spirits has culminated in the development of luminaires that not only exude beauty but also deliver unparalleled technical precision.

ITALIAN DESIGN

Florence's vibrant history as an epicenter of global artistic, cultural and commercial innovation is inherently personified in Exenia's product designs. The company is epitomized by dedicated craftsmanship, multi-generational learning, and a passion for style and ingenuity.



EXENIA'S EUROPEAN FACILITY IS SET AMONGST THE ROLLING GREEN HILLS OF THE TUSCANY REGION, WHERE NATURE IS A SOURCE OF INSPIRATION AND AN INTEGRAL PART OF THE COMPANY'S DESIGN PHILOSOPHY

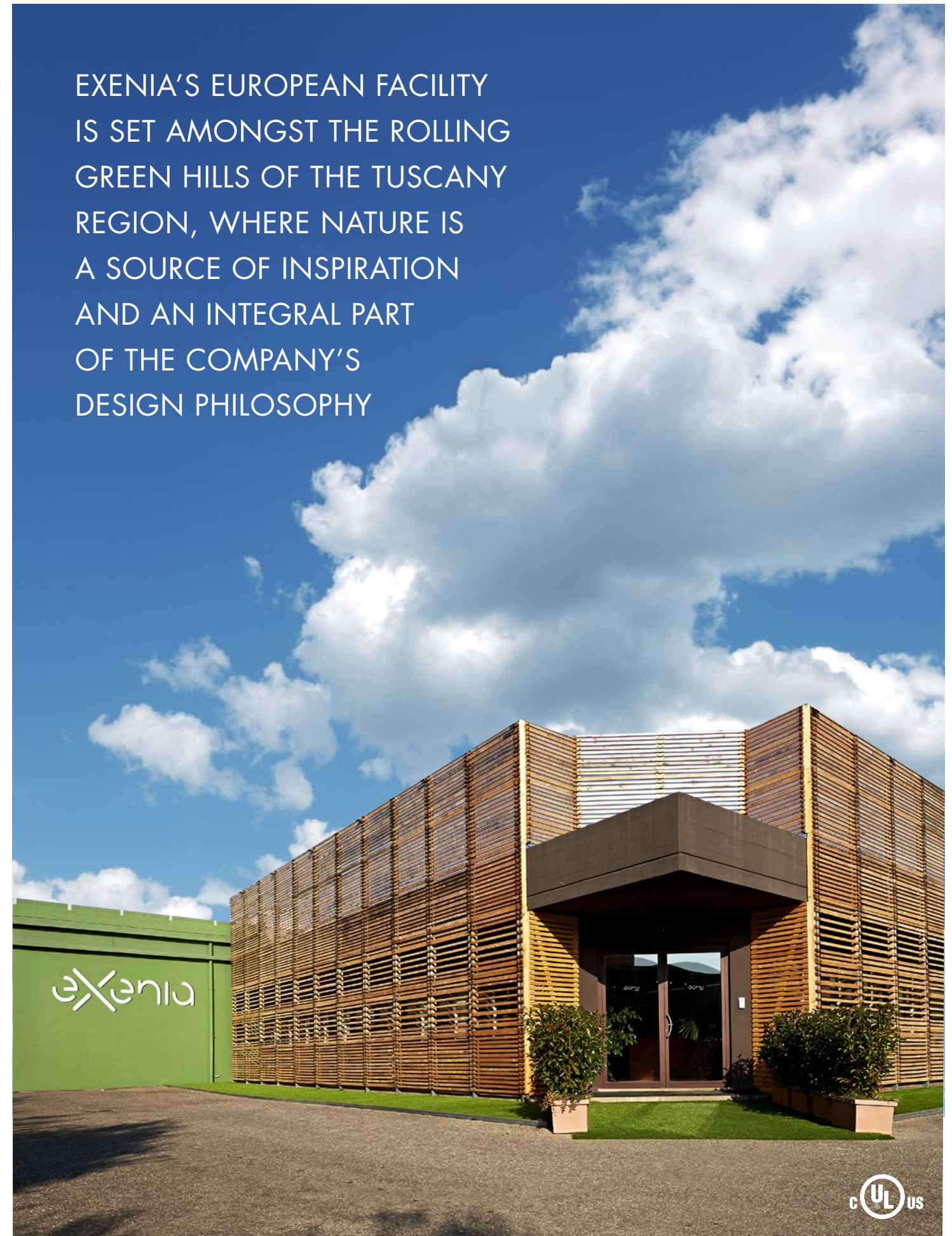

TEAM SPIRIT, PASSION,
AND PLAYFULNESS ARE ALL
HIGHLY PRIZED ASPECTS OF
LIFE AT EXENIA



Exenia Pendants

Pendants are inherently decorative; they are designed to be seen, they have a presence, even when unlit. Exenia's command of paints, textures, and finishes make our pendants especially striking. The vast choice of colored finishes makes them highly applicable to any color scheme or type of space for work or leisure. Exenia pendants can be used in various interior applications, from hospitality and retail to airports and institutions.

LOWERED LIGHT PLANE

Use Exenia Pendants to add a more human scale to grander architectural spaces – creating a lower virtual ceiling plane in an otherwise cavernous space. Or, use them to demarcate different zones – a seating area, a dining area, or a reception area. Optically, they perform as ambient lighting, illuminating a wide area or as task lighting suspended a couple of feet above a bar, table, or worktop.

WIDE RANGE OF OUTPUTS

Exenia Pendants are available with a wide range of outputs, from 500 to 7000 lumens, making them useful for any purpose, whether creating a warm, intimate glow over a reception desk or illuminating large public spaces, lobbies, and atriums.



Precision, Performance

Exenia's high-performance luminaires have been designed to help you fulfill important project goals relating to energy saving, visual comfort, lifetime, and value for money.

Efficacy

Up to 120 lm/W
(Average of 88 lm/W)

UGR Range

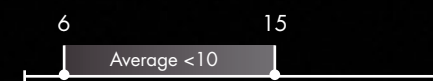

Lifetime (L70)

120,000 hours

Lifetime (L95)

19,000 hours

Outputs (Nominal)



Color Consistency

< 2SDCM



The WILLY

- Glossy White



- Glossy Yellow



- Corten



- Matte Black



Playful yet powerful, the WILLY is a picture-perfect example of Exenia's mastery in handling paint and finishes. The modern, bright Glossy finishes and the more muted Matte finishes are consistently smooth and flawless. Glossy finishes ensure an overt presence that can be striking and unique in a space, while matt finishes add an understated elegance. Exenia's command of textured finishes adds depth, drama, and style to an area.

Exenia's Corten finish is an extraordinary oxidized rust finish which is created in a controlled process to prevent further oxidization. Each piece has its own unique patina, giving each application a distinctive signature.

WILLY

DECORATIVE BEZEL FINISHES
IN A RAINBOW OF FLAVORS



The WILLY 48V

Track-mounted pendants are fantastic for multi-functional spaces such as bars, restaurants, canteens, or function rooms, where table layouts are apt to change and where you want the freedom to change the lighting layout.



WILLY Applications

Use narrow beams of warm light over bars and tables to create an inviting atmosphere. By day, the pendants take on a sculptural look of their own.





WILLY SUMMARY

Optics

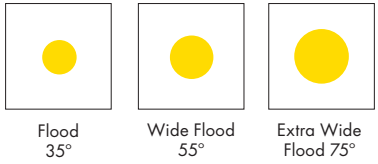

Fixture Finishes



Inner Bezel Finishes



Mounting and Cable Option Finishes

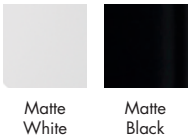

Outputs (Depending on Optic and Size)
700lm | 1300lm | 2000lm | 3500lm

Color Rendering Options
CRI 90+ | CRI 95+

NOTE: Some exceptions, consult specification sheets for details.

Sizes

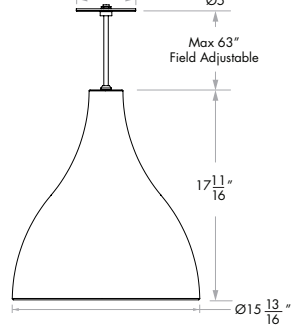
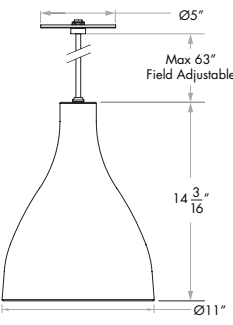
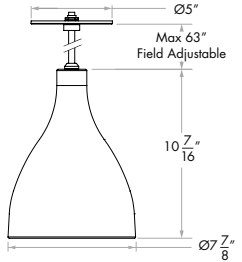
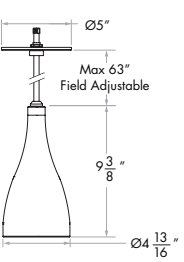
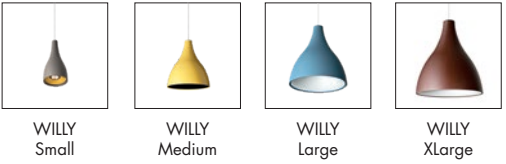

- Control Options**
- On/Off control
 - 0-10V Dimming 1%
 - Phase Dimming 1%

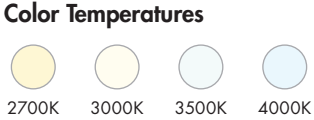

Certifications



The SHOP

With its striking 24-inch footprint, SHOP commands attention with its masterfully applied glossy and matte finishes. Designed to be seen even when unlit, SHOP's array of colors adapt to different types of architecture – from hotel lobbies, workspaces, and restaurants.

With a range of optics and outputs up to 9000lm (HO Direct/Indirect), SHOP can light large, open spaces or be suspended from height to create a more intimate setting. An optional indirect lighting component allows you to light the ceiling as well as the ground.



SHOP

DECORATIVE BEZEL FINISHES
THAT MUTE OR SING



SHOP Applications

With a balance between design and technology, aesthetics and effectiveness, the Exenia SHOP is ideal for large spaces and public environments—excellent lighting uniformity with a minimalist yet colorful design.

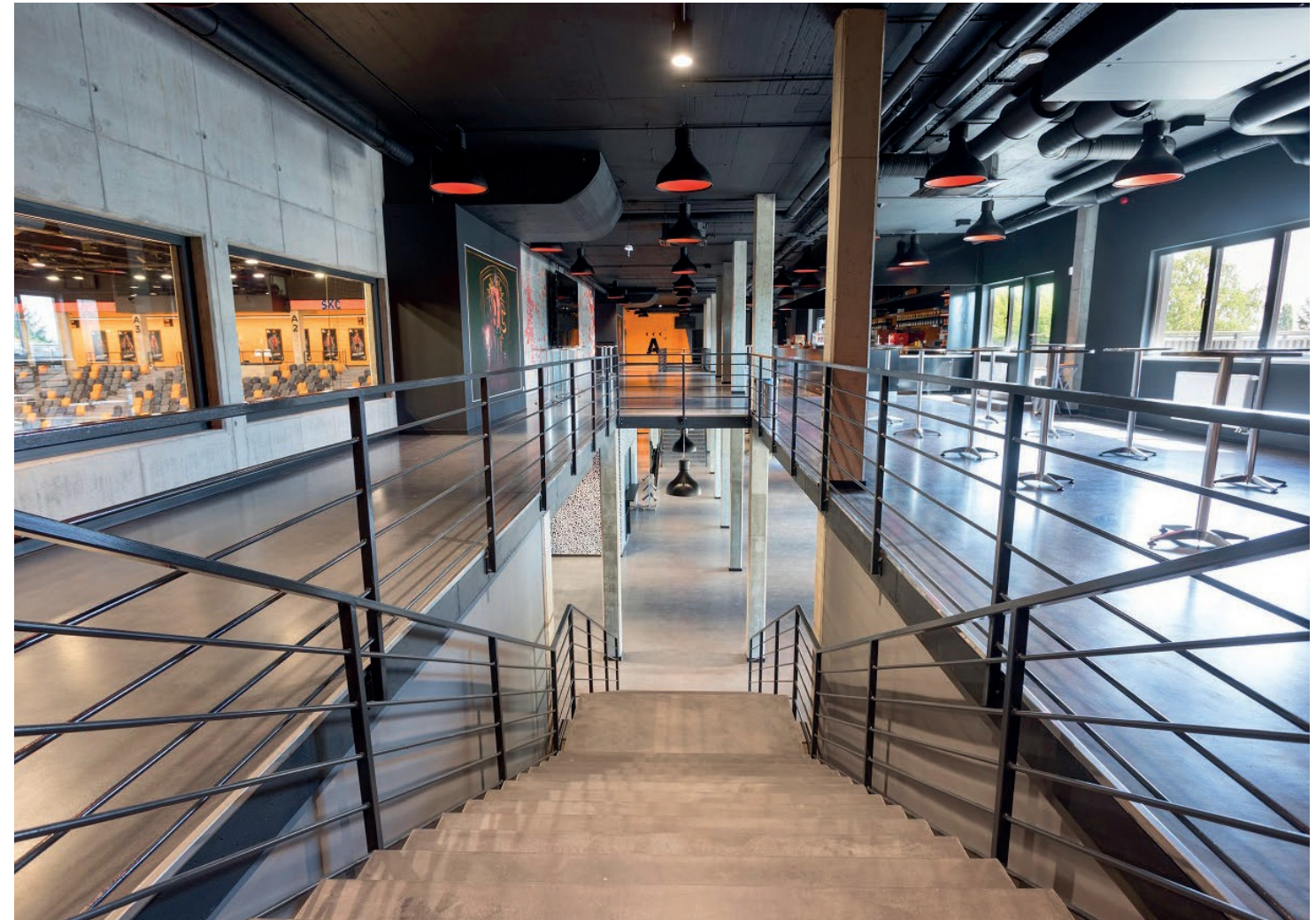



SHOP SUMMARY

Optics

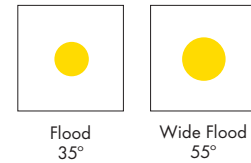

Fixture Finishes

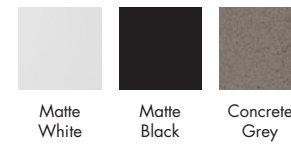

Bezel Finishes

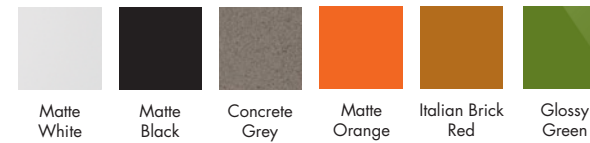

Mounting and Cable Option Finishes

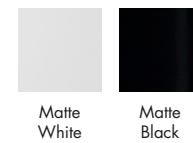

Outputs

Direct RO Output: 6500 lm
 Direct RO Direct/Indirect Outputs: 8000 lm, 8500 lm
 Direct HO Output : 7000 lm
 Direct HO Direct/Indirect Output: 9000 lm

Color Rendering Options

CRI 90+ | CRI 95+

Control Options

- On/Off control
- 0-10V Dimming 1%
- Phase Dimming 1%

Color Temperatures

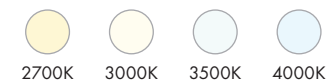

Sizes

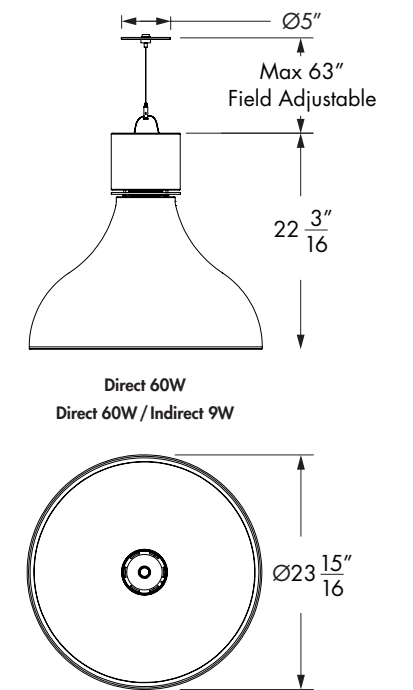

NOTE: Some exceptions, consult specification sheets for details.



Corporate Headquarters

1220 Marie-Victorin Blvd.
Longueuil, QC
J4G 2H9 Canada

T +1.877.937.3003
T +1.514.937.3003
F +1.514.937.6289

U.S. Sales Office

14 Beacon Street, Suite 301
Boston, MA
02108 United States

T +1.877.937.3003
T +1.617.307.5700
F +1.617.350.9912

info@lumenpulse.com
www.lumenpulse.com

© Lumenpulse™

2024/03
158327

